



Cornell University
Center for Advanced Computing

MapReduce and Hadoop

Aaron Birkland
Cornell Center for Advanced Computing

January 2012



Motivation

- Simple programming model for Big Data
 - Distributed, parallel – but hides this
- Established success at petabyte scale
 - Internet search indexes, analysis
 - Google, yahoo facebook
- Recently: 8000 nodes sort 10PB in 6.5 hours
- Open source frameworks with different goals
 - Hadoop, phoenix
- Lots of research in last 5 years
 - Adapt scientific computation algorithms to MapReduce, performance analysis



A programming model with some nice consequences

- $\text{Map}(D) \rightarrow \text{list}(K_i, V_i)$
- $\text{Reduce}(K_i, \text{list}(V_i)) \rightarrow \text{list}(V_f)$
- Map: “Apply a function to every member of dataset” to produce a list of key-value pairs
 - Dataset: set of values of uniform type D
 - Image blobs, lines of text, individual points, etc
 - Function: transforms each value into a list of zero or more key,value pairs of types K_i, V_i
- Reduce: Given a key and all associated values, do some processing to produce list of type V_f
- Execution over data is managed by a MapReduce framework



Canonical example: Word Count

- D = lines of text
 - K_i = Single Words
 - V_i = Numbers
 - V_f = Word/count pairs
 - $\text{Map}(D)$ = Emit pairs containing each word and the number 1
 - $\text{Reduce}(K_i, \text{list}(V_i))$ = Sum all the numbers in the list associated with the given word. Emit the word and the resulting count
- $\text{Map}(D) \rightarrow \text{list}(K_i, V_i)$**
 $\text{Reduce}(K_i, \text{list}(V_i)) \rightarrow \text{list}(V_f)$



Canonical example: Word Count

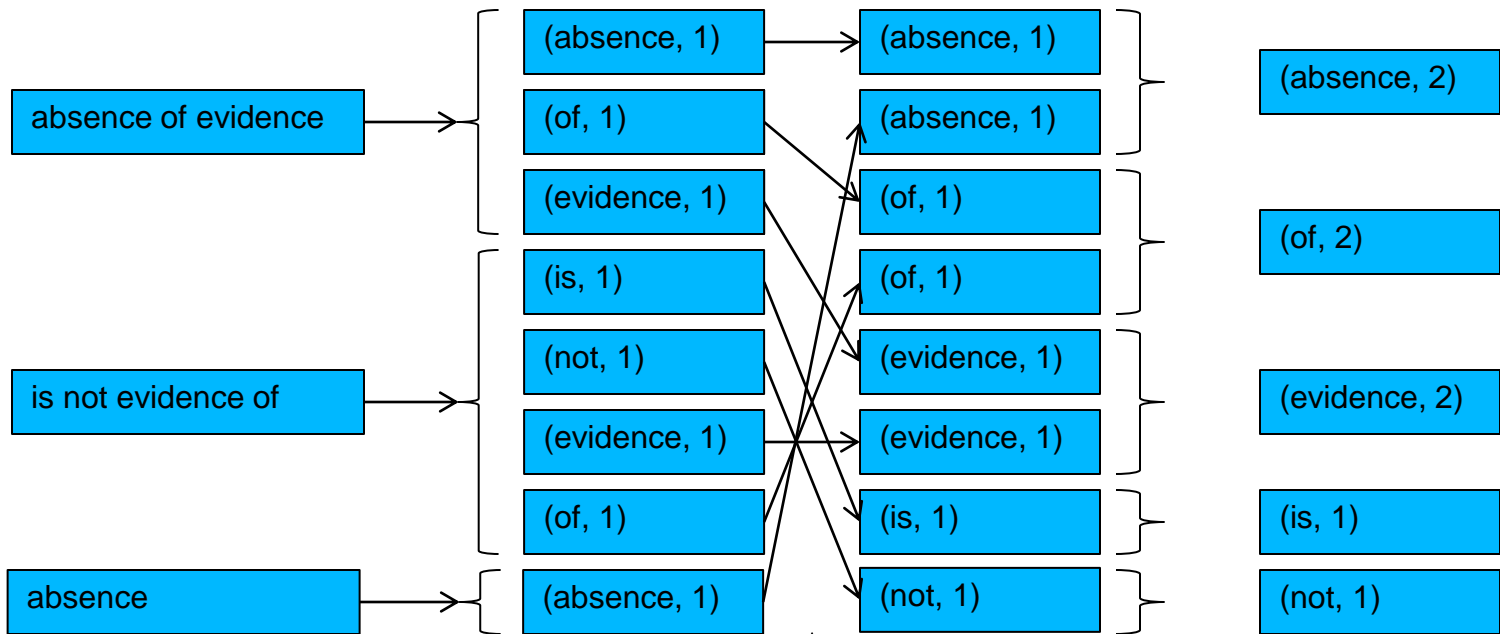

Map(D) → list(Ki, Vi)

Reduce(Ki, list(Vi)) → list(Vf)

Somehow need to group by keys so Reduce can be given all associated values!



Opportunities for Parallelism?

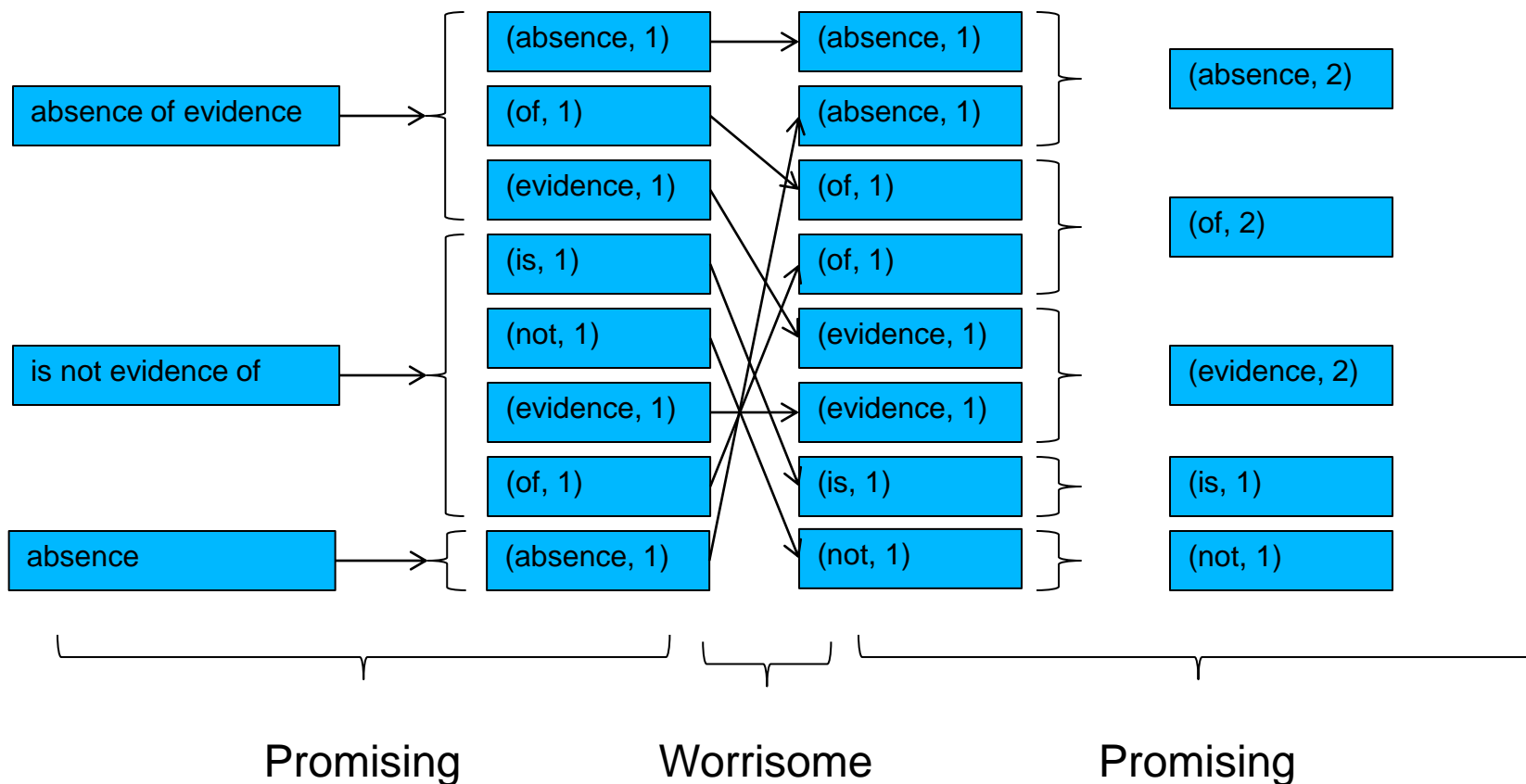



Opportunities for Parallelism

- Map and Reduce functions are independent
 - No explicit communication between them
 - Grouping phase between Map and Reduce is the only point of data exchange
- Individual Map, Reduce results depend only on input value.
 - Order of data, execution does not matter in the end.
- Input data read in parallel
- Output data written in parallel



Parallel, Distributed execution

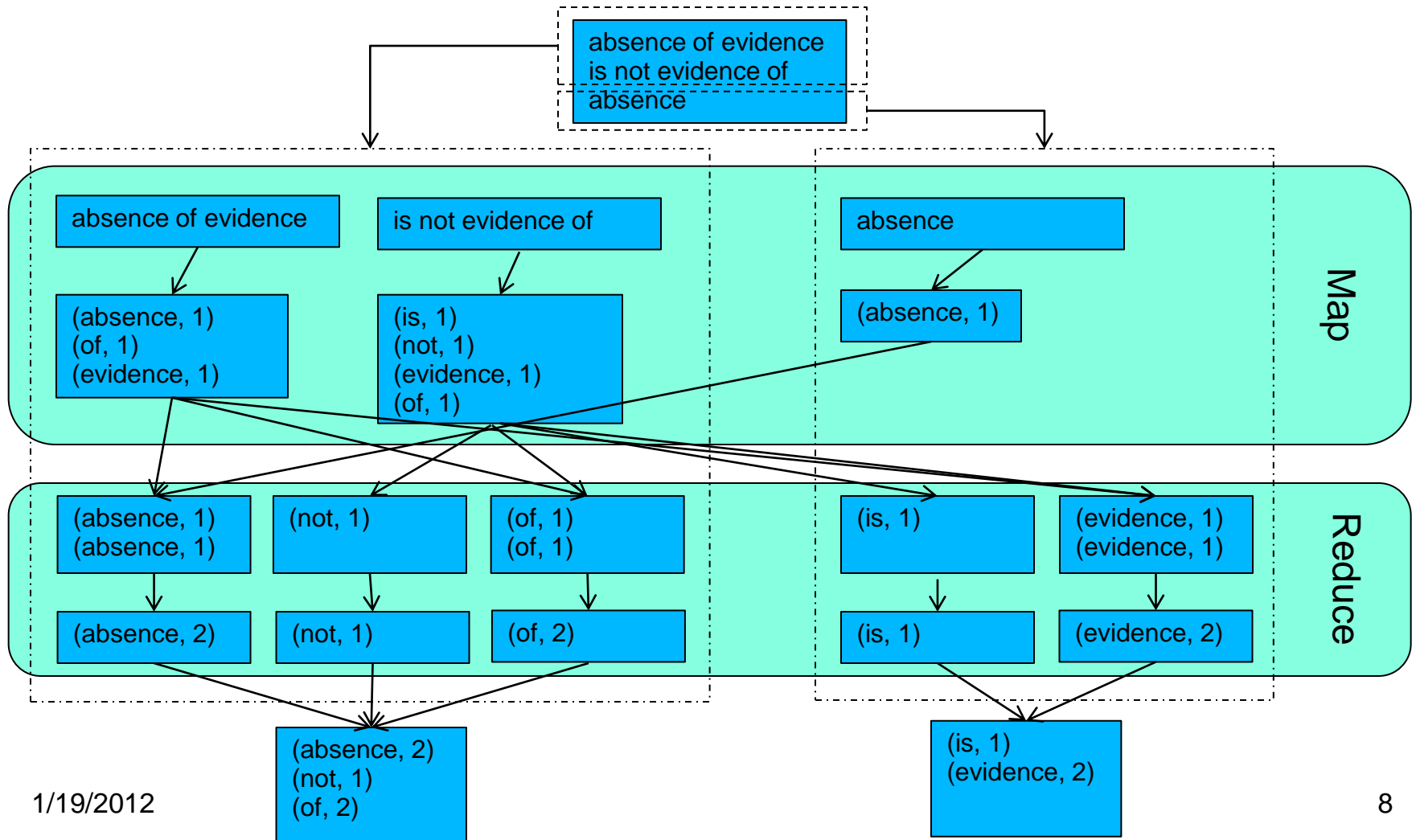



Full Parallel Pipeline

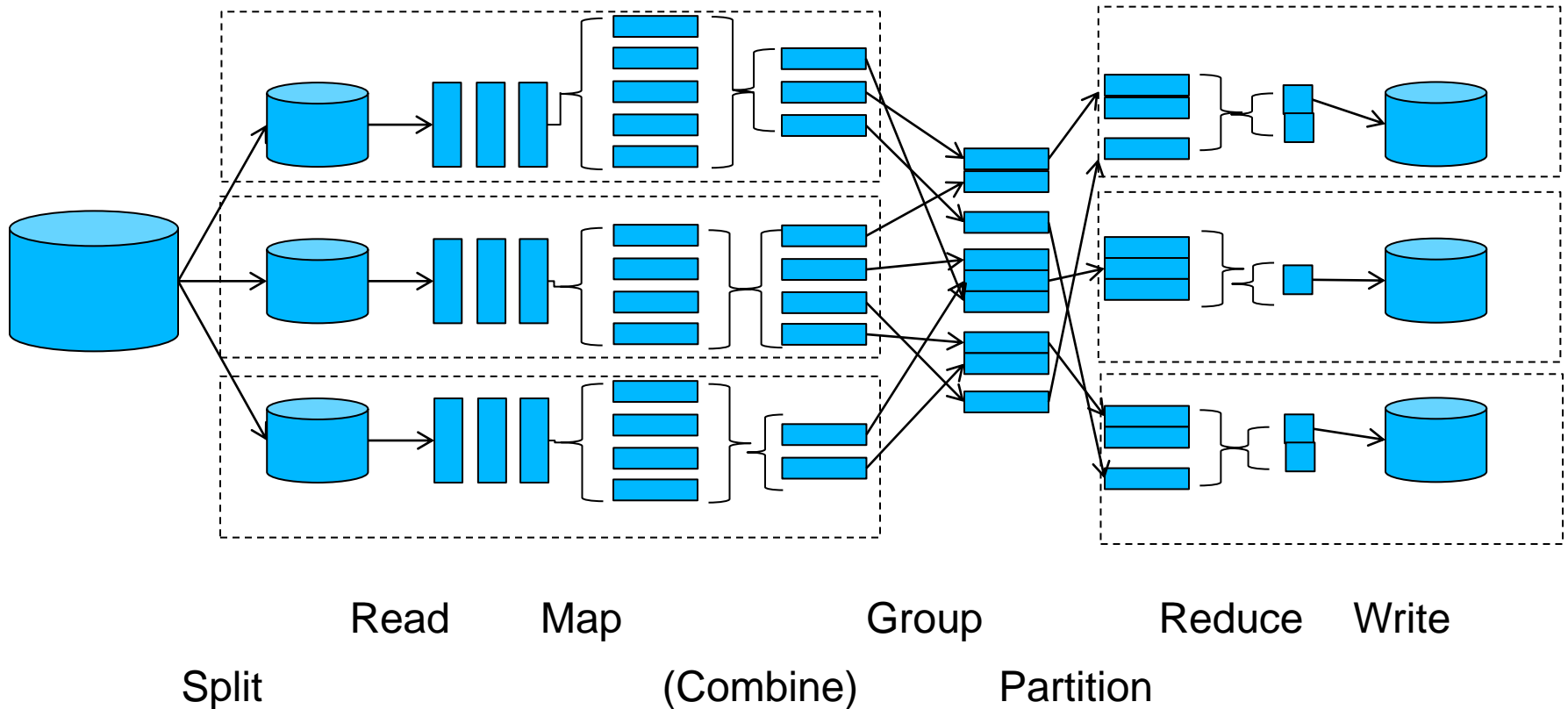



Full Parallel Pipeline

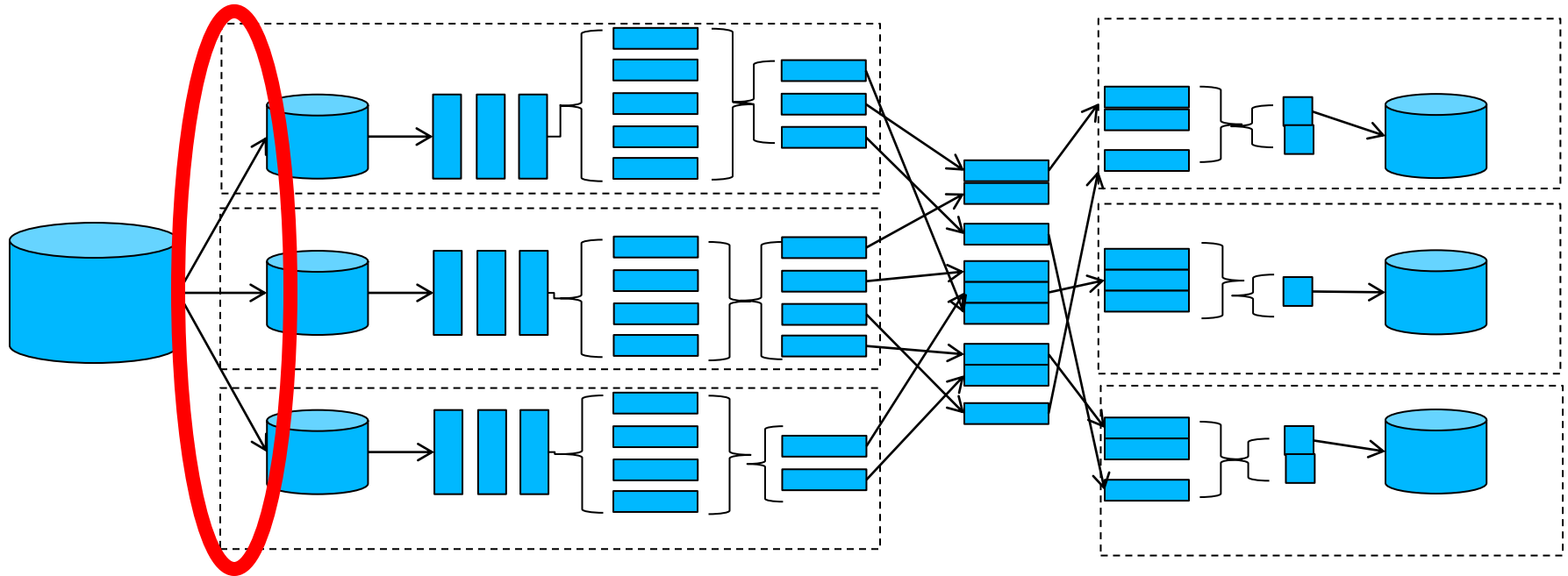

Split – Divide data into parallel streams

- Use features of underlying storage technology
 - File sharding, locality information, parallel data formats



Full Parallel Pipeline

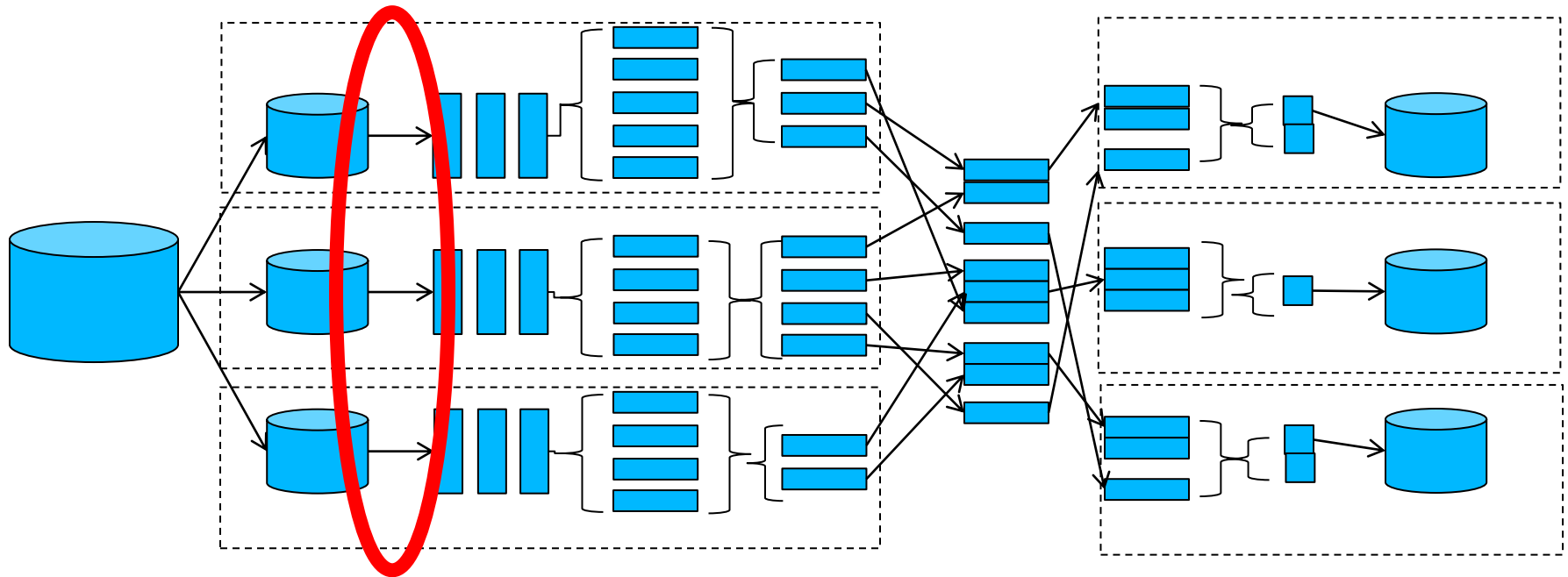

Read – Chop data into iterable units

- Most common in MapReduce world – Lines of Text
- Can be arbitrary simple or complex –integer arrays, pdf documents, mesh fragments, etc.



Full Parallel Pipeline

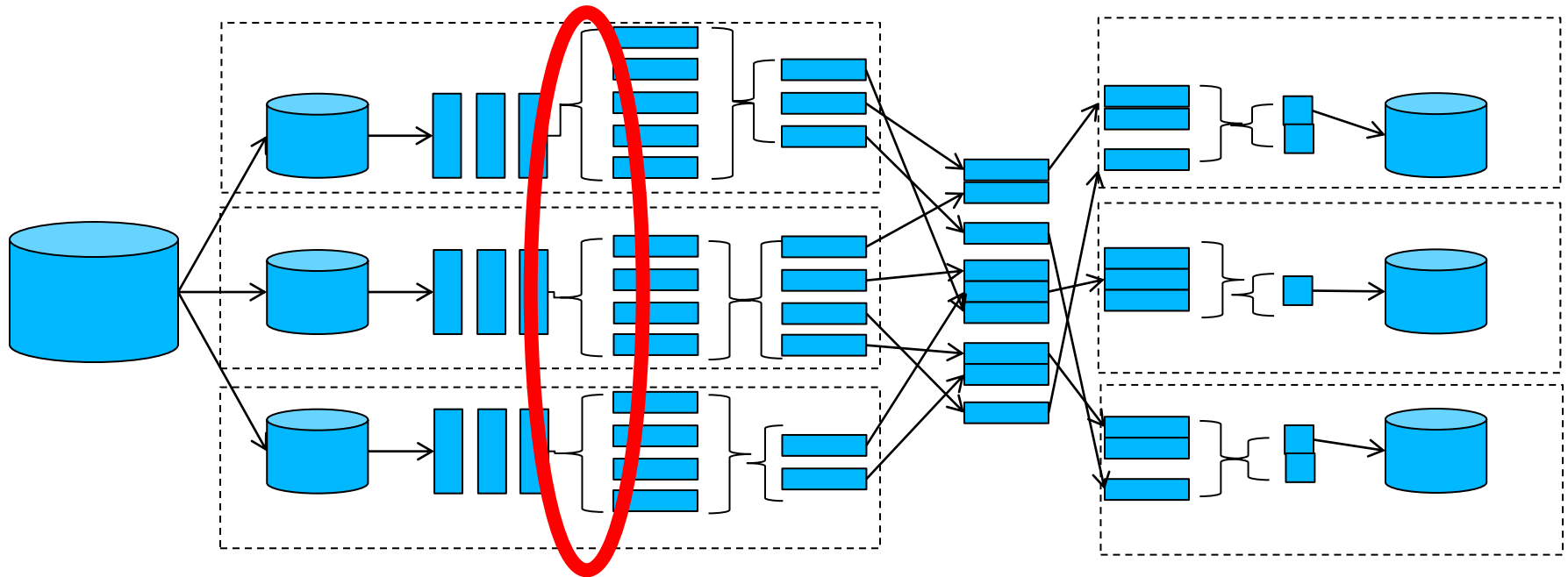

Map – Apply a function, return a list of keys/values



Full Parallel Pipeline

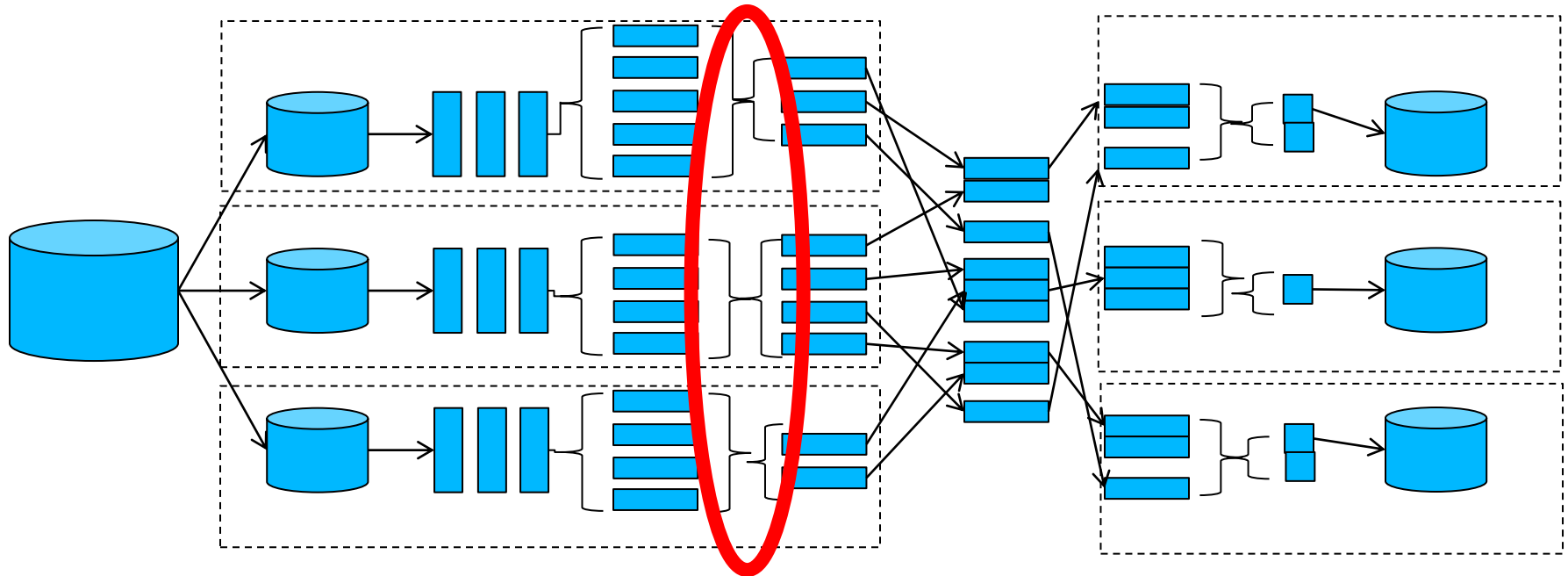

Combine – (optional) execute a “mini-reduce” on some set of map output

- For optimization purposes
- May not be possible for every algorithm



Full Parallel Pipeline

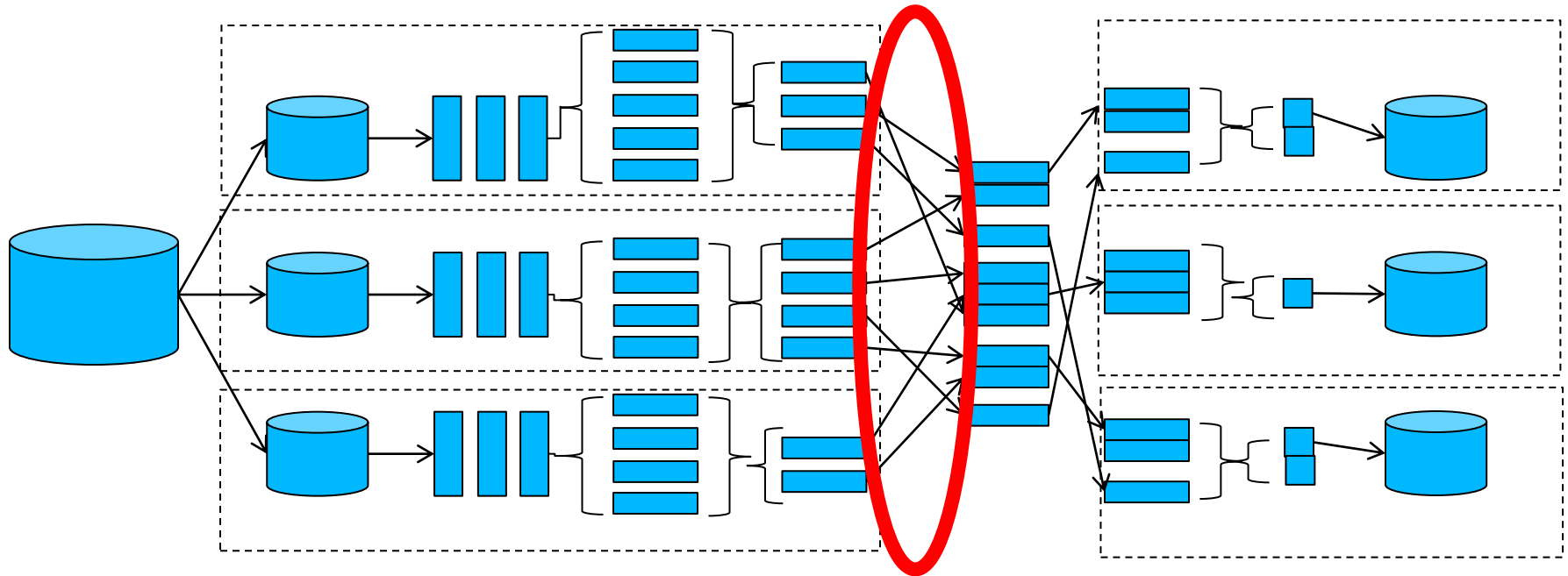

Group – Group all results by key, collapse into a list of values for each key

- Need **all** intermediate values before this can complete
- Automatically performed by MapReduce framework



Full Parallel Pipeline

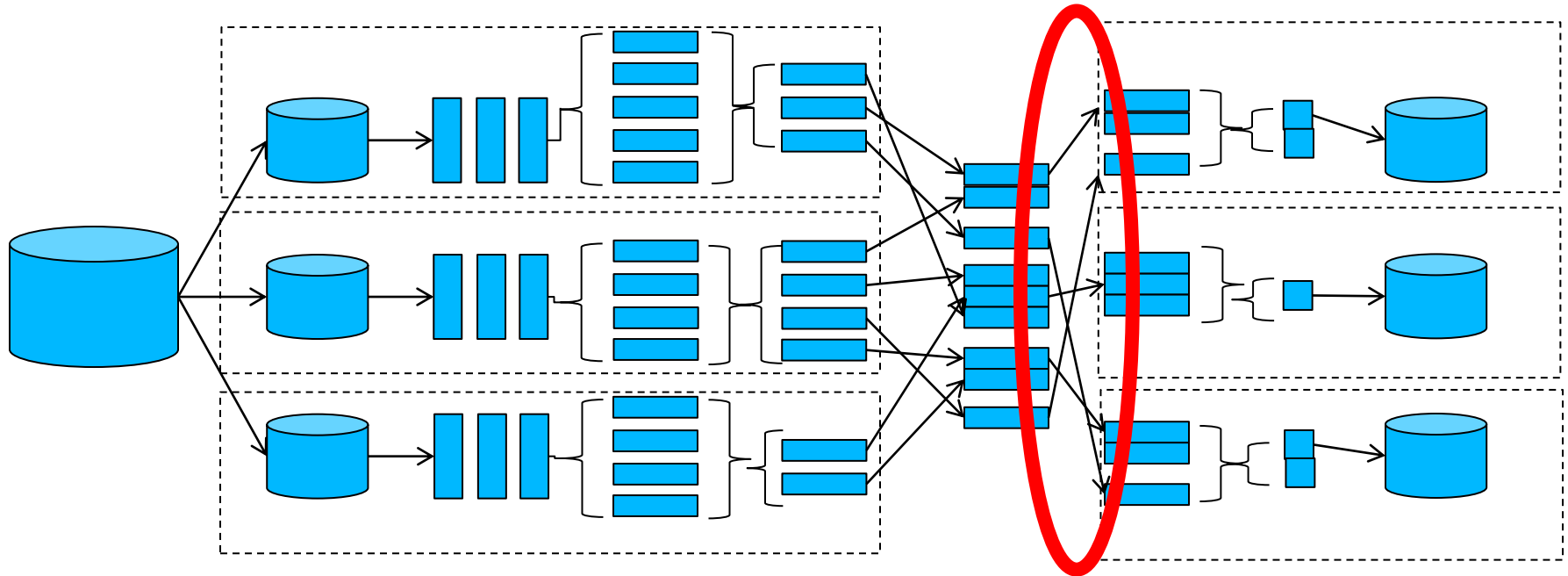

Partition – Send grouped data to reduce processes

- Typically, just a dumb hash to evenly distribute
- Opportunities for balancing or other optimization.



Full Parallel Pipeline

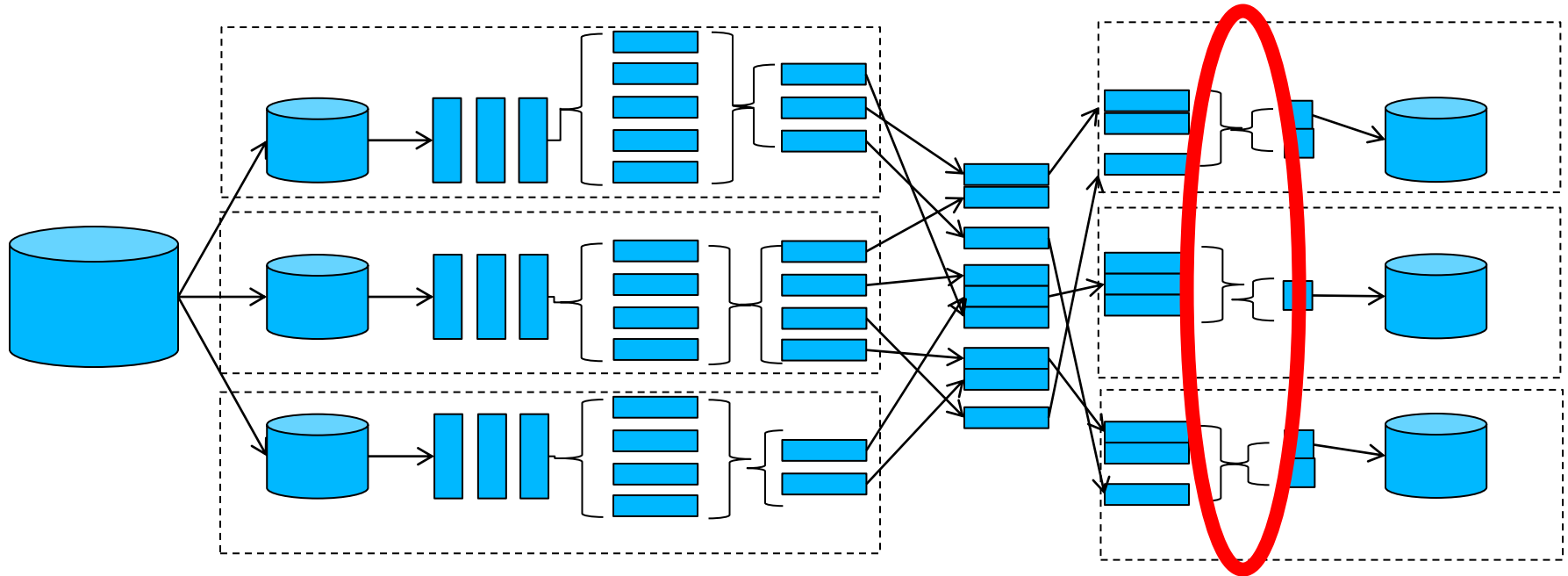

Reduce – Run a computation over each aggregated result, produce a final list of values



Full Parallel Pipeline

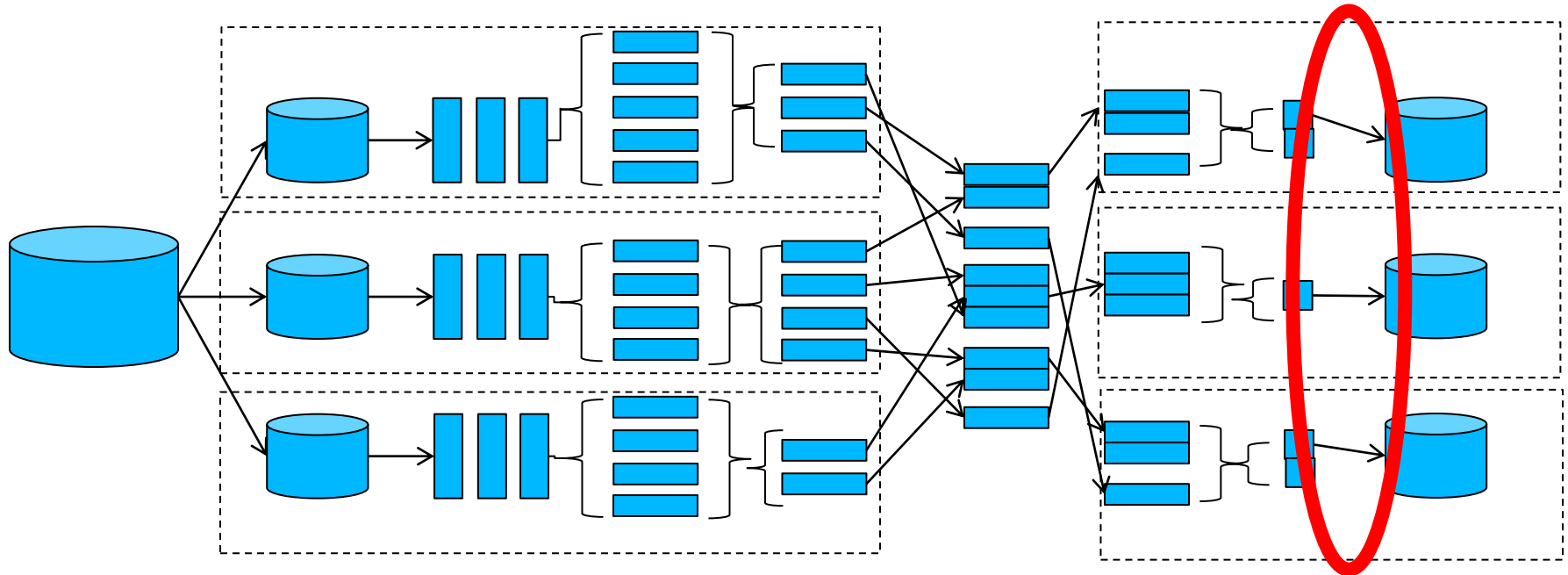

Write – Move Reduce results to their final destination

- Could be storage, or another MapReduce process!



Programming considerations

You *must* provide:

- Map, Reduce functions

You *may* provide:

- Combine, if it helps
- Partition function, if it matters

Framework must provide:

- Grouping and data shuffling

Framework may provide:

- Read, Write
 - For simple data such as lines of text
- Split
 - For parallel storage or data formats it knows about



Benefits

- Presents an easy-to-use programming model
 - No synchronization, communication by individual components. Ugly details hidden by framework.
- Execution managed by a framework
 - Failure recovery (Maps/Reduces can always be re-run if necessary)
 - Speculative execution (Several processes operate on same data, whoever finishes first wins)
 - Load balancing
- Adapt and optimize for different storage paradigms



Drawbacks

- Grouping/partitioning is serial!
 - Need to wait for **all** map tasks to complete before **any** reduce tasks can be run
- Some algorithms may be hard to conceptualize in MapReduce.
- Some algorithms may be inefficient to express in terms of Map Reduce



Hadoop

- Open Source MapReduce framework in Java
 - Spinoff from Nutch web crawler project
- HDFS – Hadoop Distributed Filesystem
 - Distributed, fault-tolerant, sharding
- Many sub-projects
 - Pig: Data-flow and execution language. Scripting for MapReduce
 - Hive: SQL-like language for analyzing data
 - Mahout: Machine learning and data mining libraries
 - K-means clustering, Singular Value Decomposition, Bayesian classification



Hadoop

- User provides java classes for Map, Reduce functions
 - Can subclass or implement virtually every aspect of MapReduce pipeline or scheduling
- Streaming mode to STDIN, STDOUT of external map, reduce processes (can be implemented in any language)
 - Lots of scientific data that goes beyond lines of text
 - Lots of existing/legacy code that can be adapted/wrapped into a Map or Reduce stage.

```
stream -input /dataDir/dataFile  
-file myMapper.sh -mapper "myMapper.sh"  
-file myReducer.sh -reducer "myReducer.sh"  
-output /dataDir/myResults
```



HDFS

- Data distributed among compute nodes
 - Sharding: 64MB chunks
 - Redundancy
- Small number of large files
- Not quite POSIX file semantics
 - No random write, append
- Write-once read many
- Favor throughput over latency
- Streaming/sequential access to files



HDFS

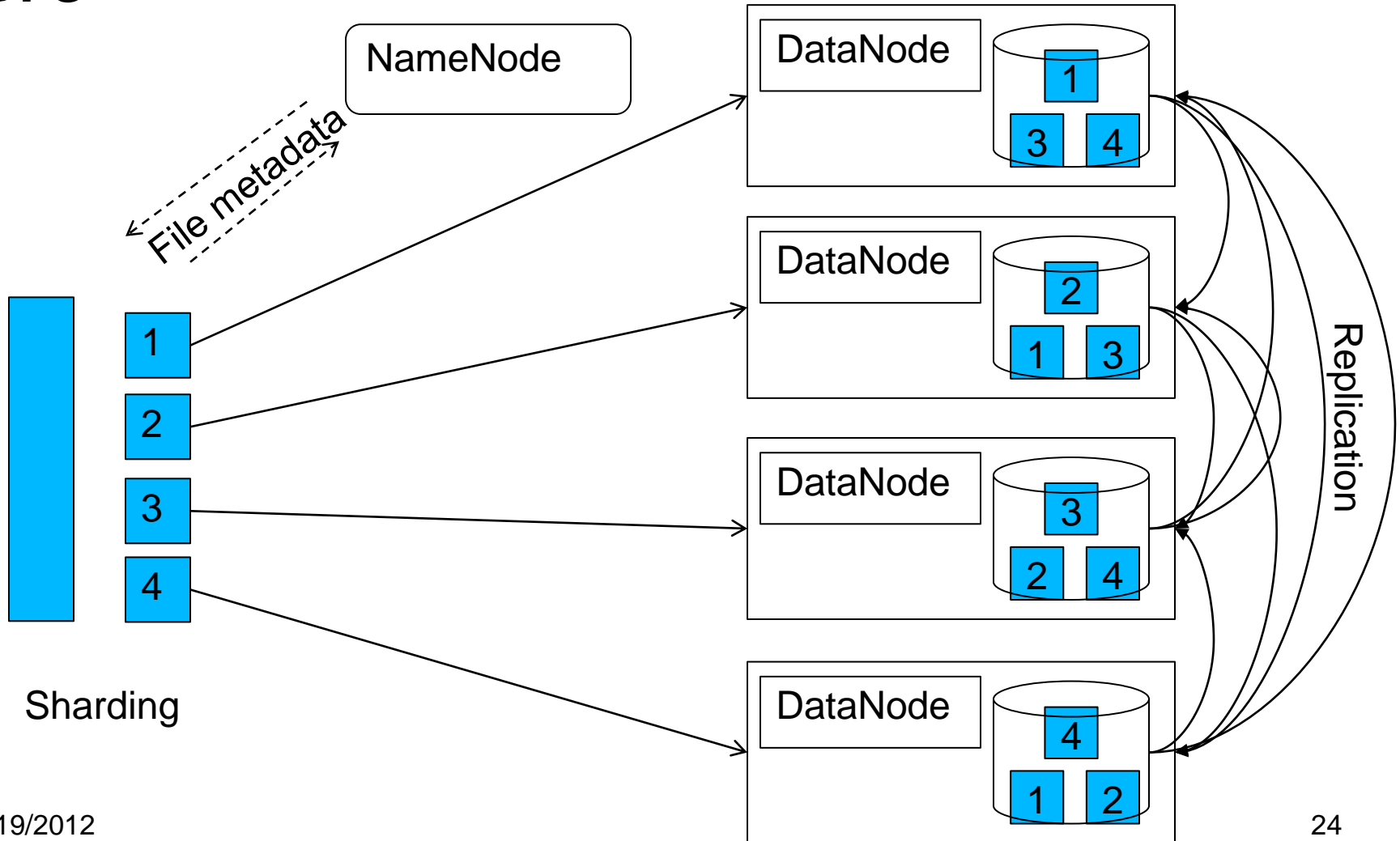



HDFS + MapReduce

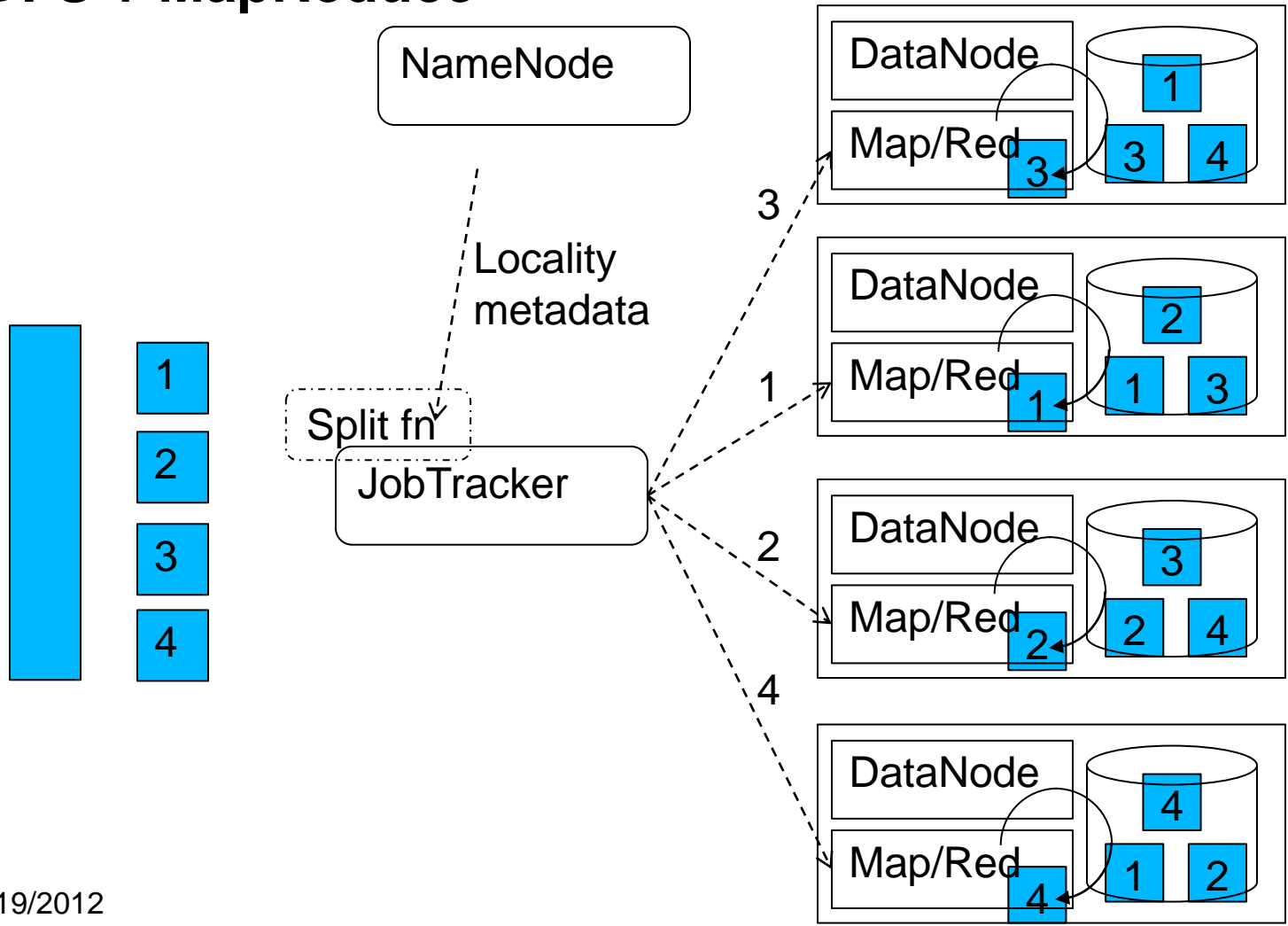



HDFS + MapReduce

- Assume failure-prone nodes
 - Data and computation recovery through redundancy
- Move computation to data
 - Data is local to computation, direct-attached storage to each node
- Sequential reads on large blocks
- Minimal contention
 - Simultaneous maps/reduces on a node can be controlled by configuration



Hadoop + HDFS vs HPC

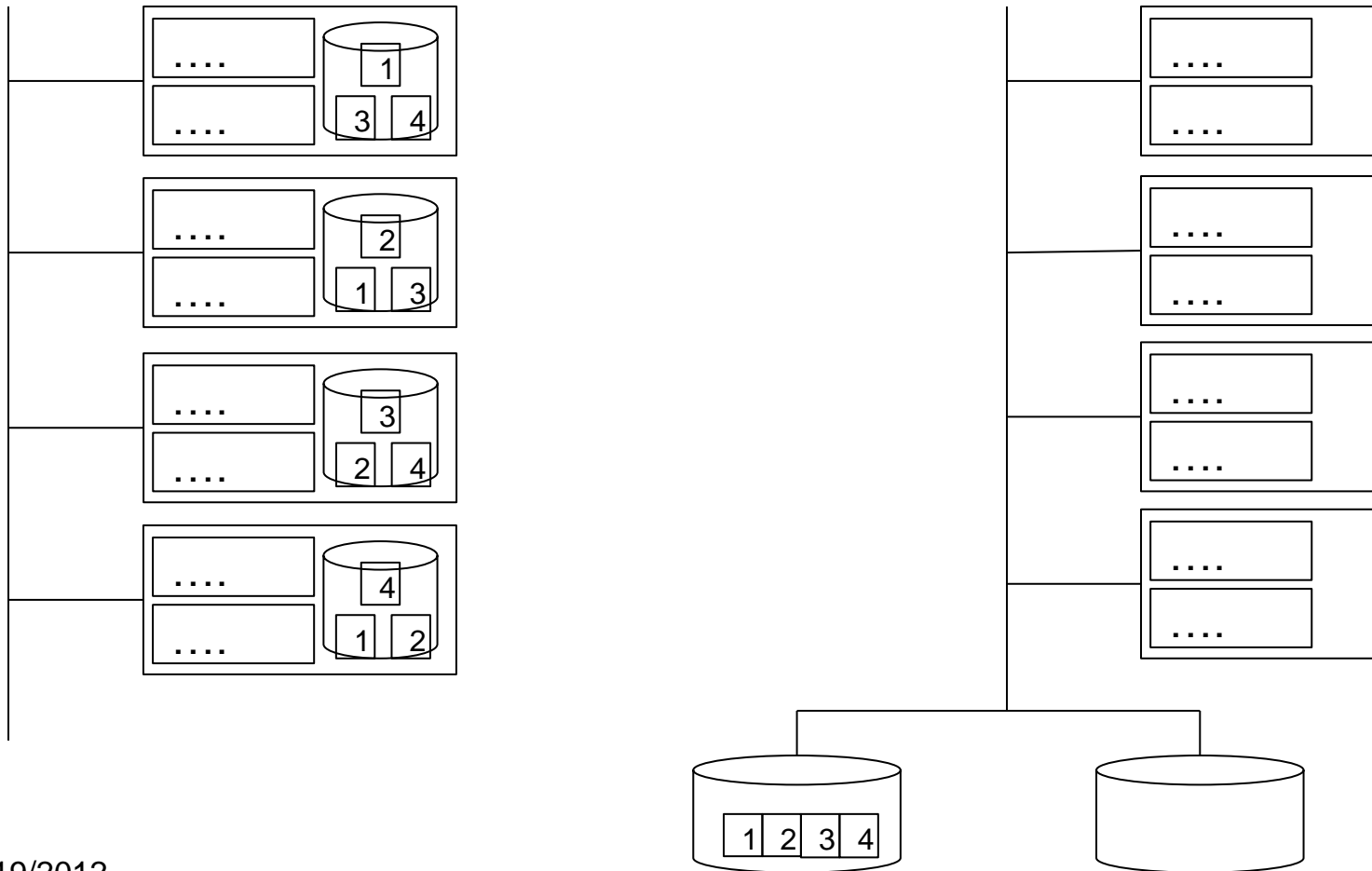



Hadoop in HPC environments

- Access to local storage can be problematic
 - Local storage may not be available at all
 - Even if so, long-term HDFS usually not possible
- HPC relies on global storage (e.g. Lustre) via high-speed interconnect.
 - What is meaning of “locality” in inherently non-local (but parallel) storage?



Hadoop @ TACC

- On *Longhorn* visualization cluster
- Special, local, persistent /hadoop filesystem on some machines
 - 48 nodes with 2TB HDFS storage/node
 - 16 nodes with 1TB HDFS storage/node, extra large memory (144GB memory)
- Modified hadoop distribution
 - Starts HDFS on allocated nodes
- Special Hadoop queue
- By request only
- Details at <https://sites.google.com/site/tacchadoop>



Dark Matter Halo Detection on Longhorn

- 200 TB simulated astronomy data
- Explore algorithms for identifying halo candidates by analyzing star density
- Compared compute parallel vs HDFS+MapReduce Data Parallel
 - ~57k data points/node/hr for compute parallel
 - ~600k data points/node/hr data parallel with MapReduce + HDFS



BLAST at NERSC

- Streaming API
- Issues with data format.
 - FASTA: sequence represented on multiple lines
 - >some sort of header
 - ACTGCATCATCATCATCAT
 - GGGCTTACATCATCATCAT
 - Lots of effort re-implementing basic data handling components (Reader, possibly Split)
 - Eventually re-formatted data so each sequence was on own line
- Overall performance: Not significantly better than existing parallel methods



Still much to learn

- Most established patterns are from web and text processing (inverted indexes, ranking, clustering, etc)
- Scientific data and algorithms much more varied
 - Papers describing an existing problem applied to MapReduce are common
- When does HDFS provide benefit over traditional global shared FS?
 - Tends to do poorly for small tasks, can be a crossover point that needs to be found
- Lots of tuning parameters
 - Data skew and heterogeneity may lead to long, inefficient jobs.



Why Hadoop?

- If you find the programming model simple/easy
- If you have a data intensive workload
- If you need fault tolerance
- If you have dedicated nodes available
- If you like Java
- If you want to experiment.